

**BroilyGrill**

**CHANGE  
YOUR WAY  
TO GRILL**



**BroilyGrill**



**100% made  
in ITALY**

**The perfect total searing in a  
professional cooking equipment**



**850°C**

**IN FEW  
MINUTES**

**CHAR-GRILLED  
WITHOUT  
CHARCOAL**

# What is BroilyGrill?

It is the ideal solution, the dream of every griller, a **high temperature direct cooking broiler**, the perfect total searing in a professional kitchen.

Directly from the USA experience, this **100% Made in Italy BBQ** is designed for the best steakhouses, hamburgeries, pubs, restaurants, **with new generation gas burners, honeycomb ceramic plates capable of reaching 850 °C in a few minutes of preheating**, drastically reducing traditional cooking times.

Furthermore, the positioning of the heat source in the upper part allows for a **direct radiation cooking**, creating an **immediate Maillard reaction** and a perfect total searing never seen before, **avoiding the annoying emission of smoke, flames, and smells** caused by the classic systems of cooking.

Broilygrill represents the professional revolution, a very high-performance appliance, simple to use, perfect for show cooking kitchens, suitable for multiple uses.



**Reverse cooking  
with heat radiation  
from the top  
to the bottom.**

# Advantages

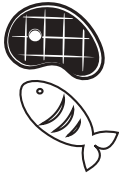

**PERFECT TOTAL SEARING:** The three basic cooking principles (*radiation*, *conduction* and *convection*) are available in a single machine. All the direct cooking white and red meat (hamburger, ribs, Fiorentina steaks, tomahawk, thin slices of chicken, pork or lamb) will have a fantastic Maillard, a perfect and homogeneous brazing, with an incomparable succulence. The BBQ case creates the “**oven effect**”, an added convection effect that cooks the crown of the ingredient in a perfect and homogeneous way on the entire grill area (perfect total searing).



**COOKING WITHOUT SMOKE AND SMELLS:** reverse cooking with heat radiation from above drastically **reduces the amount of smoke** that normally develops in classic systems **up to 80%**, creating a highly digestible product without added smoke or charcoal taste. Forget the flames and the burnt or cold inside steaks, the unpleasant smells and smoke caused by pyrolysis in traditional cooking systems.



**HEATING SPEED:** BroilyGrill reaches **850 °C in few minutes**. You turn on the pilot and wait for the order.



**COOKING SPEED:** thanks to the reached high temperatures, **cooking times are reduced on average by 50%**, with a consequent increase in productivity. Very high performance in hamburger restaurants! Up to 360 hamburger each hour (12 pcs every 2 minutes).



**ENERGY SAVING:** the speed of heating and cooking allows the machine to be used only in case of need, deleting unnecessary energy waste.



**VERSATILITY:** Combined to LTC (low temperature cooking) with grill finishing it is the maximum expression of gourmet cuisine and it boosts the creativity of starred chefs by offering the tool to cook chicken, pork, thick steaks with bone, vegetables and shellfish in a sublime way.



**EASY CLEANING:** cooking grills and trays are removable and dishwasher safe. It is possible to clean the internal casing with drain hole on the bottom.

**WITHOUT  
SMOKE  
AND  
SMELLS**



# Technical features

## BRL8001 GAS

- Nr. 2 upper ceramic gas burners with high efficiency.
- Temp. 850 °C and single ignition, with gas tap with safety valve, thermocouple, pilot.
- Repetitive battery lighter.
- Realized entirely in stainless steel AISI 304.
- Nr. 3 strong high conduction grills in AISI 304 stainless steel, adjustable in height on 8 levels, removable for easy cleaning.
- Tray on guides to contain cooking residues, removable at the same time of the cooking grill.
- Nr. 3 removable pans placed on the bottom of the cooking chamber.
- Cooking chamber bottom with drain for an easy cleaning.

## BRE8001 ELECTRIC

- Nr. 1 high efficiency radiant plate with double ignition, with 3 power levels regulation.
- Realized entirely in stainless steel AISI 304.
- Strong high conduction grills in AISI 304 stainless steel, adjustable in height on 8 levels, removable for easy cleaning.
- Tray on guides to contain cooking residues, removable at the same time of the cooking grill.
- Nr. 3 removable pans placed on the bottom of the cooking chamber.
- Cooking chamber bottom with drain for an easy cleaning.

	BRL8001 GAS	BRE8001 ELETTRICO
External dimensions mm	980x450/630x745h	1050x450/630x745h
Useful cooking area mm	700x380	700x380
Power Supply	GAS	ELECTRIC
kW	12,8	10,0
		3NAc400V 50 Hz 32A
Weight kg	87	93
Certification	CE	CE

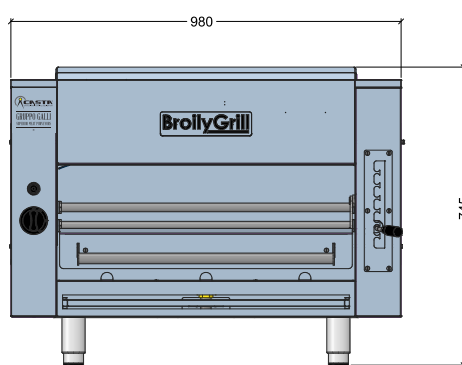
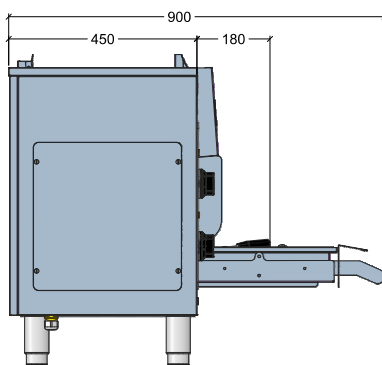

BRL8001

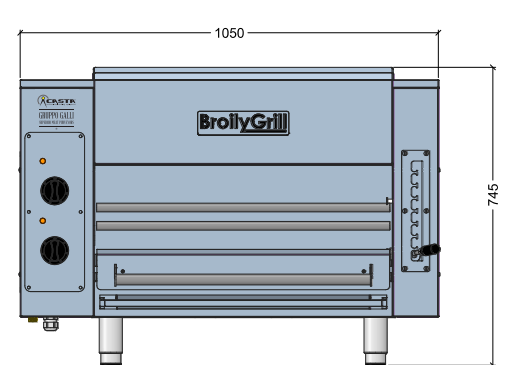

BRE8001



**- 50%  
COMPARED  
TO NORMAL  
COOKING TIMES**



**ENERGY  
SAVING**

# Direct radiation cooking

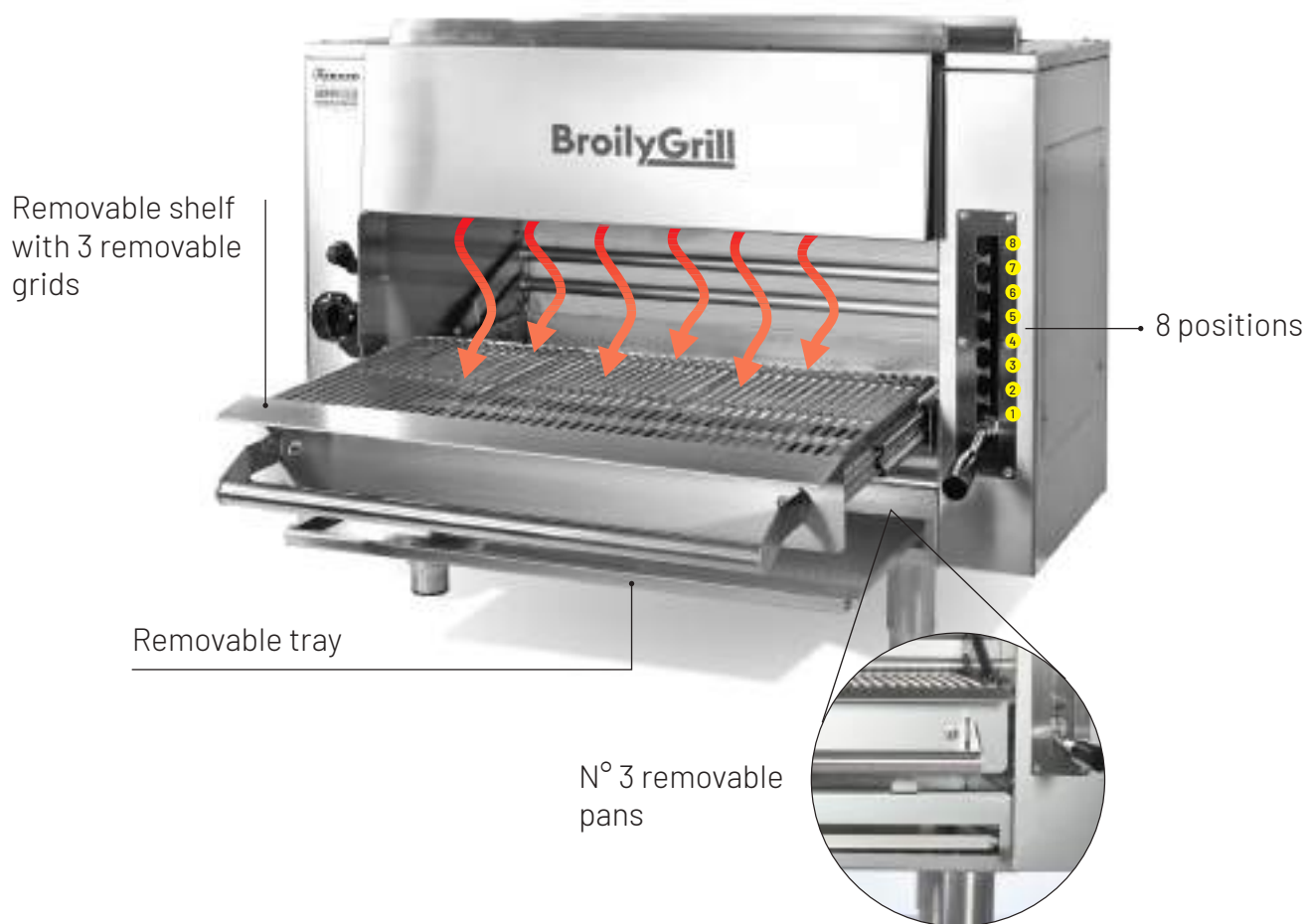

**PERFECT  
TOTAL  
SEARING**



**The  
dream  
of every  
griller**

# BroilyGrill



Casta 1-3 - Via F.lli Lumière, 11 - Casta 2 - Via F.lli Lumière, 30  
(Z.I. Villa Selva) - 47122 Forlì (FC) Italy - Tel. +39 0543 782920  
[www.casta.com](http://www.casta.com)