

Ventless Hood

Model FSH-5



- The compact and simple design of the ventless hood eliminates the need for expensive roof modifications and the hassle of dealing with multiple vendors for separate hood and electrical systems.
- Our one-of-a-kind, type 1, stainless steel hood provides vapor removal requirements for a variety of food service applications and equipment.
- The Giles Ventless Hood uses an Ansul R-102A fire suppression system. Our system contains piping, plenum nozzles, and conduit for routing the fusible link cable through the hood. Final installation, charging, and testing of the system must be performed by an authorized Ansul distributor. This is the sole responsibility of the customer and is not included in the hood purchase.

Design Features

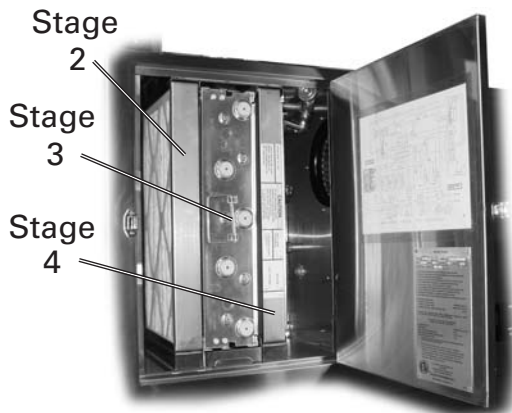

Ventless Hood System

This Ventless Hood consists of a Four-stage Air Purification System.

- Stage 1.** Two Stainless Steel Baffle Filters trap large grease particles. (Not Shown)
- Stage 2.** Two Disposable Pre-Filters trap smaller grease particles.
- Stage 3.** Two Electrostatic Air Cleaning Filters (EAC) use ionizers to charge particles of dirty air allowing them to be collected by an electrostatic force.
- Stage 4.** Two Disposable Charcoal Filters help eliminate odor.

Appliance Constrains

Equipment Type	Max. Input Power (kW)	Max. Cooking Temperature	Max. Shortening Capacity	Max. Cooking Area
Fryers	20 (per fryer) 40 (total)	400°F [204°C]	80 lbs [36kg] (per fryer) 160 lbs [72kg] (total)	380 in ² [0.245m ²] single fryer, 760 in ² [0.490m ²] any combination
Ovens	55	500°F [260°C]	N/A	60" [1524mm]L X 42" [1067mm]D
Griddles	25	400°F [204°C]	N/A	48" [1219mm]L X 26" [660mm]D
Ranges	25	400°F [204°C]	N/A	48" [1219mm]L X 26" [660mm]D

Note: To be used with electric appliances only.

Ventless Hood

Model FSH-5

Item No.: _____
 Quantity: _____
 Project Name: _____
 SIS#: _____
 AIA/CSI#: _____

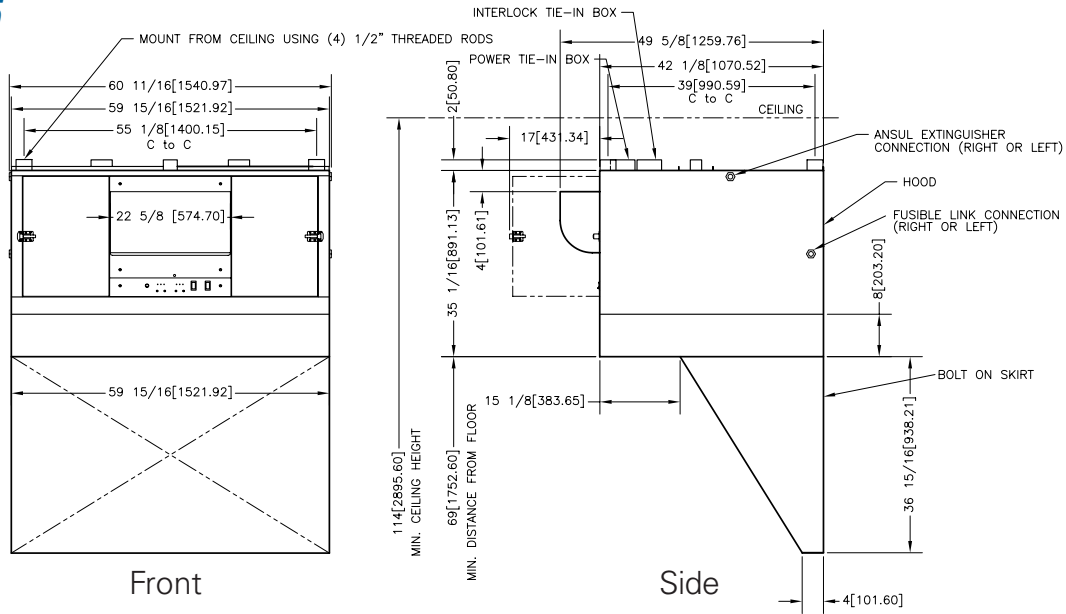

Inches [millimeters]

Specifications

We reserve the right to change specifications and product design without notice. Such revisions do not entitle the buyer to corresponding changes, improvements additions or replacements on previously purchased equipment.

Construction:

20Ga to 18Ga Stainless Steel

Dimensions:

Width: 60-11/16" [1547 mm]

Depth: 49-5/8" [1260 mm]

Height: 74" [1880 mm]

Ventless Hood:

Exhaust CFM: 840-940

Approx. Decibel Level: 73

Uncrated Weight: 464 lbs [211 kg]

Electrical Specifications:

Available voltages: 208/220/240

1 phase - 208/220/240V - 8/8/8 AMPS

(No service cord provided)

Product Designation:

FSH-5 (see "How to Specify" below)

Shipping Specifications:

Crated Weight: 664 lbs [302 kg]

Crated Cube Size: 82" X 56" X 50" = 132.87 cu ft

[2082mm X 1422mm X 1270mm = 3.762 cu meters]

Accessories Included

Unit is shipped with (2) Baffle Filters, (2) Pre-Filters, (2) EAC Filters, (2) Charcoal Filters, (2) EAC Soak Tanks and (1) Manual.

How To Specify

1. Local Codes

Ensure your local codes permit Ventless Hoods.

2. Appliance Constraints

Ensure the appliance is within the specified constraints of the hood. (See Appliance Constraints on the front page or contact Giles Enterprises)

3. Location

Ensure the location you are installing the Ventless Hood meets the proper clearances specified above.

4. Electrical Specifications

Determine the electrical specifications from the available Voltages, Hz., and Phase.

5. ILS Option (Interlocking Start)

Specify if your county requires the hood to shut-down if the appliance underneath is not operating. Check with your local officials for this requirement.

6. Determine FSH-5 Part Number

Specify the part number from the following:

	Voltage	Hz.	Phase	ILS	Part Number
<input type="checkbox"/>	208/240	60	1	No	79269
<input type="checkbox"/>	208/240	60	1	Yes	79582
<input type="checkbox"/>	220	50	1	No	70533
<input type="checkbox"/>	220	50	1	Yes	70534

7. Accessories (additional charges)

Specify the part number and quantity of the following accessory items needed:

	Qty	Description	Part Number
<input type="checkbox"/>		Pre-Filter	46762
<input type="checkbox"/>		EAC Filter (Left-side)	20521
<input type="checkbox"/>		EAC Filter (Right-side)	20520
<input type="checkbox"/>		Charcoal Filter	32056

8. Shipping

Specify the shipping method

Giles Foodservice Equipment

2750 Gunter Park Drive West • Montgomery, AL 36109 USA
 334.272.1457 • Fax 334.272.3518 • Phone Toll Free 1.800.554.4537
 Web Site: www.gilesent.com • Email: info@gilesent.com

Ventless Hood

Model FSH-6



- The compact and simple design of the ventless hood eliminates the need for expensive roof modifications and the hassle of dealing with multiple vendors for separate hood and electrical systems.
- Our one-of-a-kind, type 1, stainless steel hood provides vapor removal requirements for a variety of food service applications and equipment.
- The Giles Ventless Hood uses an Ansul R-102A fire suppression system. Our system contains piping, plenum nozzles, and conduit for routing the fusible link cable through the hood. Final installation, charging and testing of the system must be performed by an authorized Ansul distributor. This is the sole responsibility of the customer and is not included in the hood purchase.

Design Features

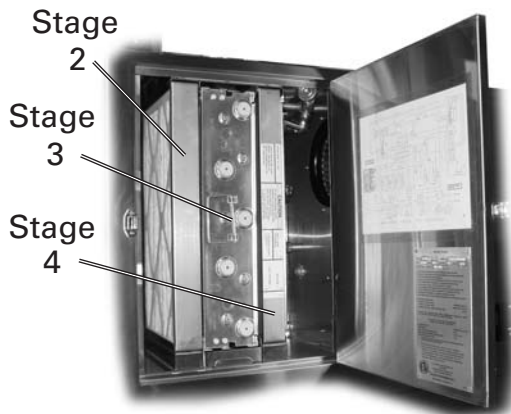

Ventless Hood System

This Ventless Hood consists of a Four-stage Air Purification System.

- Stage 1.** Two Stainless Steel Baffle Filters trap large grease particles. (Not Shown)
- Stage 2.** Two Disposable Pre-Filters trap smaller grease particles.
- Stage 3.** Two Electrostatic Air Cleaning Filters (EAC) use ionizers to charge particles of dirty air, allowing them to be collected by an electrostatic force.
- Stage 4.** Two Disposable Charcoal Filters help eliminate odor.

Appliance Constrains

Equipment Type	Max. Input Power (kW)	Max. Cooking Temperature	Max. Shortening Capacity	Max. Cooking Area
Fryers	20 (per fryer) 40 (total)	400°F [204°C]	80 lbs [36kg] (per fryer) 160 lbs [72kg] (total)	380 in ² [0.245m ²] single fryer, 760 in ² [0.490m ²] any combination
Ovens	55	500°F [260°C]	N/A	72"[1829mm]L X 42"[1067mm]D
Griddles	25	400°F [204°C]	N/A	60"[1524mm]L X 26"[660mm]D
Ranges	25	400°F [204°C]	N/A	60"[1524mm]L X 26"[660mm]D

Note: To be used with electric appliances only.

Ventless Hood

Model FSH-6

Item No.: _____
 Quantity: _____
 Project Name: _____
 SIS#: _____
 AIA/CSI#: _____

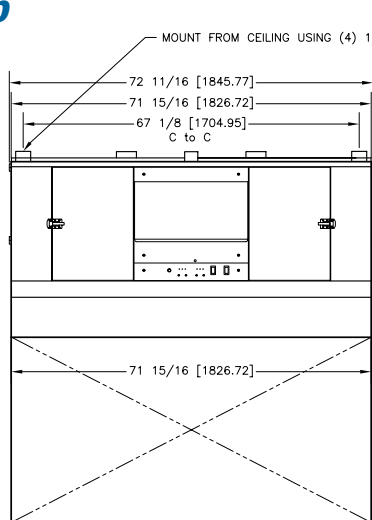

Front

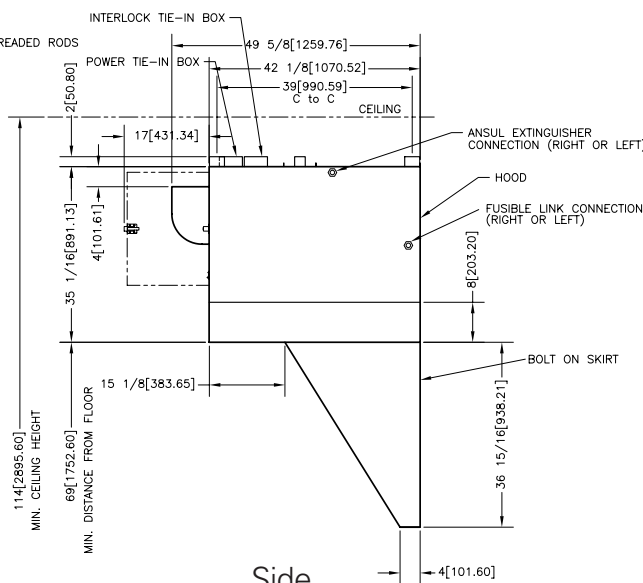

Side

Inches [millimeters]

Specifications

We reserve the right to change specifications and product design without notice. Such revisions do not entitle the buyer to corresponding changes, improvements additions or replacements on previously purchased equipment.

Construction:

20Ga to 18Ga Stainless Steel

Dimensions:

Width: 72-11/16" [1846 mm]

Depth: 49-5/8" [1260 mm]

Height: 74" [1880 mm]

Ventless Hood:

Exhaust CFM: 840-940

Approx. Decibel Level: 73

Uncrated Weight: 553 lbs [251 kg]

Electrical Specifications:

Available voltages: 208/220/240

1 phase - 208/220/240V - 8/8/8 AMPS

(No service cord provided)

Product Designation:

FSH-6 (see "How to Specify" below)

Shipping Specifications:

Crated Weight: 733 lbs [333 kg]

Crated Cube Size: 82" X 56" X 50" = 132.87 cu ft

[2082mm X 1422mm X 1270mm = 3.762 cu meters]

Accessories Included

Unit is shipped with (2) Baffle Filters, (2) Pre-Filters, (2) EAC Filters, (2) Charcoal Filters, (2) EAC Soak Tanks and (1) Manual.

How To Specify

1. Local Codes

Ensure your local codes permit Ventless Hoods.

2. Appliance Constraints

Ensure the appliance is within the specified constraints of the hood. (See Appliance Constraints on the front page or contact Giles Enterprises)

3. Location

Ensure the location you are installing the Ventless Hood meets the proper clearances specified above.

4. Electrical Specifications

Determine the electrical specifications from the available Voltages, Hz., and Phase.

5. ILS Option (Interlocking Start)

Specify if your county requires the hood to shut-down if the appliance underneath is not operating. Check with your local officials for this requirement.

6. Determine FSH-6 Part Number

Specify the part number from the following:

	Voltage	Hz.	Phase	ILS	Part Number
<input type="checkbox"/>	208/240	60	1	No	78973
<input type="checkbox"/>	208/240	60	1	Yes	70591
<input type="checkbox"/>	220	50	1	No	70535
<input type="checkbox"/>	220	50	1	Yes	70536

7. Accessories (additional charges)

Specify the part number and quantity of the following accessory items needed:

	Qty	Description	Part Number
<input type="checkbox"/>		Pre-Filter	46762
<input type="checkbox"/>		EAC Filter (Left-side)	20521
<input type="checkbox"/>		EAC Filter (Right-side)	20520
<input type="checkbox"/>		Charcoal Filter	32056

8. Shipping

Specify the shipping method

Giles Foodservice Equipment

2750 Gunter Park Drive West • Montgomery, AL 36109 USA
 334.272.1457 • Fax 334.272.3518 • Phone Toll Free 1.800.554.4537
 Web Site: www.gilesent.com • Email: info@gilesent.com



Ventless Hood

Model FSH-5



- The compact and simple design of the ventless hood eliminates the need for expensive roof modifications and the hassle of dealing with multiple vendors for separate hood and electrical systems.
- The Giles Ventless Hood is a one-of-a-kind, type 1, stainless steel unit, which incorporates our patented Electrostatic Air Cleaner and patent pending Ultra Violet light, providing vapor removal requirements for various models of fryers.
- The fire suppression system used in your Giles Ventless Hood is an Ansul R-102A fire suppression system. Our system contains piping, plenum nozzles, and conduit for routing the fusible link cable through the hood. Final installation, charging, and testing of the system is required to be performed by an authorized Ansul distributor. This is the sole responsibility of the customer and is not included in the hood purchase.

Design Features

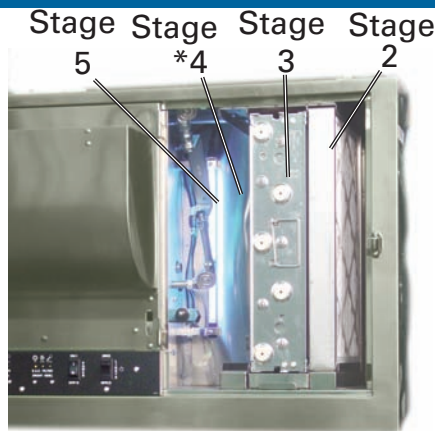

Ventless Hood System

This Ventless Hood consists of a Five-stage Air Purification System.

- Stage *1.** Two Stainless Steel Baffle Filters trap large grease particles.
- Stage 2.** Two Disposable Pre-Filters trap smaller grease particles.
- Stage 3.** Two Electrostatic Air Cleaning Filters (EAC) use ionizers to charge particles of dirty air allowing them to be collected by an electrostatic force.
- Stage *4.** Two Disposable Charcoal Filters help eliminate odor.
- Stage 5.** Two Ultra Violet Lamps help eliminate any remaining grease laden vapors and improve emission control.

(* Not Shown)

Appliance Constraints

Equipment Type	Max. Input Power (kW)	Max. Cooking Temperature	Max. Shortening Capacity	Max. Cooking Area
Fryers	20 (per fryer) 40 (total)	400°F [204°C]	80 lbs [36kg] (per fryer) 160 lbs [72kg] (total)	380 in ² [0.245m ²] single fryer, 760 in ² [0.490m ²] any combination
Ovens	55	500°F [260°C]	N/A	60" [1524mm] L X 42" [1067mm] D
Griddles	25	400°F [204°C]	N/A	48" [1219mm] L X 26" [660mm] D
Ranges	25	400°F [204°C]	N/A	48" [1219mm] L X 26" [660mm] D

Note: To be used with electric appliances only.

Ventless Hood

Model FSH-5



Item No.: _____
 Quantity: _____
 Project Name: _____
 SIS#: _____
 AIA/CSI#: _____

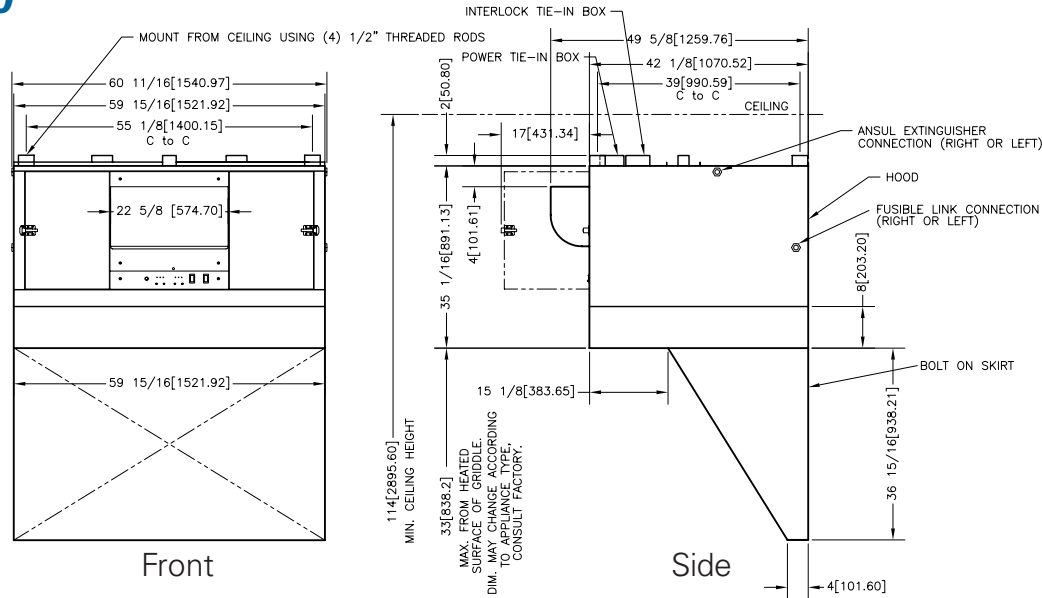

Inches [millimeters]

Specifications

We reserve the right to change specifications and product design without notice. Such revisions do not entitle the buyer to corresponding changes, improvements additions or replacements on previously purchased equipment.

Construction:

20Ga to 18Ga Stainless Steel

Dimensions:

Width: 60-11/16" [1547 mm]

Depth: 49-5/8" [1260 mm]

Height: 74" [1880 mm]

Ventless Hood:

Exhaust CFM: 840-940

Approx. Decibel Level: 73

Uncrated Weight: 464 lbs [211 kg]

Electrical Specifications:

Available voltages: 208/220/240

1 phase - 208/220/240V - 8/8/8 AMPS

(No service cord provided)

Product Designation:

FSH-5 (see "How to Specify" below)

Shipping Specifications:

Crated Weight: 664 lbs [302 kg]

Crated Cube Size: 82" X 56" X 50" = 132.87 cu ft

[2082mm X 1422mm X 1270mm = 3.762 cu meters]

Accessories Included

Unit is shipped with (2) Baffle Filters, (2) Pre-Filters, (2) EAC Filters, (2) Charcoal Filters, (2) UV Lamps, (2) EAC Soak Tanks and (1) Manual.

How To Specify

1. Local Codes

Ensure your local codes permit Ventless Hoods.

2. Appliance Constraints

Ensure the appliance is within the specified constraints of the hood. (See Appliance Constraints on the front page or contact Giles Enterprises.)

3. Location

Ensure the location you are installing the Ventless Hood meets the proper clearances specified above.

4. Electrical Specifications

Determine the electrical specifications from the available Voltages, Hz., and Phase.

5. ILS Option (Interlocking Start)

Specify if your county requires the hood to shut-down if the appliance underneath is not operating. Check with your local officials for this requirement.

6. Ultimate Ventless Option

Ultra Violet Light

7. Accessories (additional charges)

Specify the part number and quantity of the following accessory items needed:

	Qty	Description	Part Number
<input type="checkbox"/>		Pre-Filter	46762
<input type="checkbox"/>		EAC Filter (Left-side)	20521
<input type="checkbox"/>		EAC Filter (Right-side)	20520
<input type="checkbox"/>		Charcoal Filter	32056
<input type="checkbox"/>		Ultra Violet Lamp	90226

8. Shipping

Specify the shipping method

Giles Foodservice Equipment

2750 Gunter Park Drive West • Montgomery, AL 36109 USA
 Phone 334.272.1457 • Fax 334.272.3518 • Phone Toll Free 1.800.554.4537
 Web Site: www.gilesent.com • Email: info@gilesent.com



Ventless Hood

Model FSH-6



- The compact and simple design of the ventless hood eliminates the need for expensive roof modifications and the hassle of dealing with multiple vendors for separate hood and electrical systems.
- The Giles Ventless Hood is a one-of-a-kind, type 1, stainless steel unit, which incorporates our patented Electrostatic Air Cleaner and patent pending Ultra Violet light, providing vapor removal requirements for various models of fryers.
- The fire suppression system used in your Giles Ventless Hood is an Ansul R-102A fire suppression system. Our system contains piping, plenum nozzles, and conduit for routing the fusible link cable through the hood. Final installation, charging, and testing of the system is required to be performed by an authorized Ansul distributor. This is the sole responsibility of the customer and is not included in the hood purchase.

Design Features

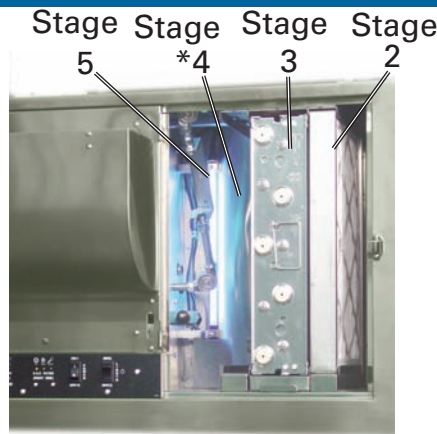

Ventless Hood System

This Ventless Hood consists of a Five stage Air Purification System.

- Stage *1.** Two Stainless Steel Baffle Filters trap large grease particles.
- Stage 2.** Two Disposable Pre-Filters trap smaller grease particles.
- Stage 3.** Two Electrostatic Air Cleaning Filters (EAC) use ionizers to charge particles of dirty air allowing them to be collected by an electrostatic force.
- Stage *4.** Two Disposable Charcoal Filters help eliminate odor.
- Stage 5.** Two Ultra Violet Lamps help eliminate any remaining grease laden vapors and improve emission control.

(* Not Shown)

Appliance Constraints

Equipment Type	Max. Input Power (kW)	Max. Cooking Temperature	Max. Shortening Capacity	Max. Cooking Area
Fryers	20 (per fryer) 40 (total)	400°F [204°C]	80 lbs [36kg] (per fryer) 160 lbs [72kg] (total)	380 in ² [0.245m ²] single fryer, 760 in ² [0.490m ²] any combination
Ovens	55	500°F [260°C]	N/A	72" [1829mm]L X 42" [1067mm]D
Griddles	25	400°F [204°C]	N/A	60" [1524mm]L X 26" [660mm]D
Ranges	25	400°F [204°C]	N/A	60" [1524mm]L X 26" [660mm]D

Note: To be used with electric appliances only.

Ventless Hood

Model FSH-6



Item No.: _____
 Quantity: _____
 Project Name: _____
 SIS#: _____
 AIA/CSI#: _____

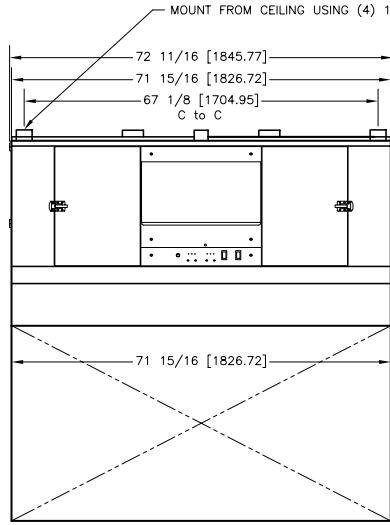

Front

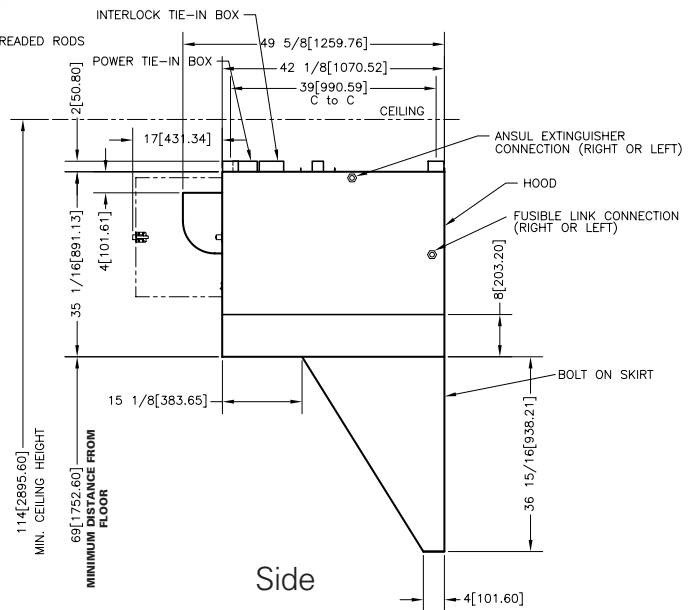

Side

Inches [millimeters]

Specifications

We reserve the right to change specifications and product design without notice. Such revisions do not entitle the buyer to corresponding changes, improvements additions or replacements on previously purchased equipment.

Construction:

20Ga to 18Ga Stainless Steel

Dimensions:

Width: 72-11/16" [1846 mm]

Depth: 49-5/8" [1260 mm]

Height: 74" [1880 mm]

Ventless Hood:

Exhaust CFM: 840-940

Approx. Decibel Level: 73

Uncrated Weight: 553 lbs [251 kg]

Electrical Specifications:

Available voltages: 208/220/240

1 phase - 208/220/240V - 8/8/8 AMPS

(No service cord provided)

Product Designation:

FSH-5 (see "How to Specify" below)

Shipping Specifications:

Crated Weight: 733 lbs [333 kg]

Crated Cube Size: 82" X 56" X 50" = 132.87 cu ft

[2082mm X 1422mm X 1270mm = 3.762 cu meters]

Accessories Included

Unit is shipped with (2) Baffle Filters, (2) Pre-Filters, (2) EAC Filters, (2) Charcoal Filters, (2) UV Lamps, (2) EAC Soak Tanks and (1) Manual.

How To Specify

1. Local Codes

Ensure your local codes permit Ventless Hoods.

2. Appliance Constraints

Ensure the appliance is within the specified constraints of the hood. (See Appliance Constraints on the front page or contact Giles Enterprises.)

3. Location

Ensure the location you are installing the Ventless Hood meets the proper clearances specified above.

4. Electrical Specifications

Determine the electrical specifications from the available Voltages, Hz., and Phase.

5. ILS Option (Interlocking Start)

Specify if your county requires the hood to shut-down if the appliance underneath is not operating. Check with your local officials for this requirement.

6. Ultimate Ventless Option

Ultra Violet Light

7. Accessories (additional charges)

Specify the part number and quantity of the following accessory items needed:

	Qty	Description	Part Number
<input type="checkbox"/>		Pre-Filter	46762
<input type="checkbox"/>		EAC Filter (Left-side)	20521
<input type="checkbox"/>		EAC Filter (Right-side)	20520
<input type="checkbox"/>		Charcoal Filter	32056
<input type="checkbox"/>		Ultra Violet Lamp	90226

8. Shipping

Specify the shipping method

Giles Foodservice Equipment

2750 Gunter Park Drive West • Montgomery, AL 36109 USA
 Phone 334.272.1457 • Fax 334.272.3518 • Phone Toll Free 1.800.554.4537
 Web Site: www.gilesent.com • Email: info@gilesent.com